

**AWT - Ringkolbenpressen**  
**AWT-Hydraulic nuts**

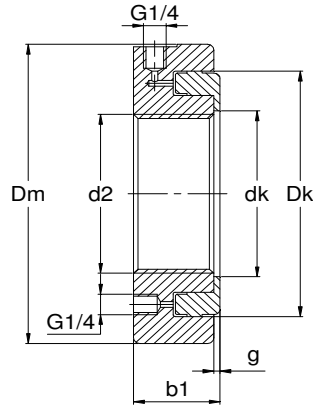

d <sub>2</sub>	Abmessungen						Gewicht	Aufpreßkraft bei 800 bar	Kurzzeichen Ringkolbenpressen	
	D <sub>m</sub>	b <sub>1</sub>	D <sub>k</sub>	d <sub>k</sub>	g	kolbenfläche				
mm						cm <sup>2</sup>	kg	kN		
<b>M 50 x 1,5</b>	110	40	88	51	2	4	30,6	2,3	245	<b>RKP 50</b>
<b>M 55 x 2</b>	118	40	92	56	2	4	31,2	2,6	250	<b>RKP 55</b>
<b>M 60 x 2</b>	125	40	96	61	2	4	31,6	2,8	253	<b>RKP 60</b>
<b>M 65 x 2</b>	132	40	103	66	3	4	35,5	3,1	284	<b>RKP 65</b>
<b>M 70 x 2</b>	140	40	110	71	3	4	41,0	3,4	328	<b>RKP 70</b>
<b>M 75 x 2</b>	145	40	116	76	3	4	44,8	3,6	359	<b>RKP 75</b>
<b>M 80 x 2</b>	150	40	122	81	3	4	49,0	3,8	392	<b>RKP 80</b>
<b>M 85 x 2</b>	155	40	126	86	3	4	49,3	3,9	394	<b>RKP 85</b>
<b>M 90 x 2</b>	160	40	130	91	3	5	50,0	4,2	395	<b>RKP 90</b>
<b>M 95 x 2</b>	165	40	136	96	3	5	52,0	4,3	416	<b>RKP 95</b>
<b>M 100 x 2</b>	170	42	142	101	3	5	54,5	4,7	435	<b>RKP 100</b>
<b>M 105 x 2</b>	175	42	147	106	6	5	56,6	4,7	153	<b>RKP 105</b>
<b>M 110 x 2</b>	180	43	152	111	6	5	59,0	5,0	470	<b>RKP 110</b>
<b>M 115 x 2</b>	185	43	157	116	6	5	60,8	5,2	487	<b>RKP 115</b>
<b>M 120 x 2</b>	190	43	162	121	6	5	63,0	5,4	504	<b>RKP 120</b>
<b>M 125 x 2</b>	195	44	167	126	7	5	65,0	5,6	520	<b>RKP 125</b>
<b>M 130 x 2</b>	200	44	171	131	7	5	65,0	5,8	520	<b>RKP 130</b>
<b>M 135 x 2</b>	205	45	176	136	7	5	66,6	6,0	533	<b>RKP 135</b>
<b>M 140 x 2</b>	210	45	182	141	7	5	69,0	6,3	552	<b>RKP 140</b>
<b>M 145 x 2</b>	215	46	186	146	7	5	70,6	6,6	565	<b>RKP145</b>
<b>M 150 x 2</b>	220	46	191	151	7	5	75,3	6,8	602	<b>RKP 150</b>
<b>M 155 x 3</b>	225	46	200	156	7	5	81,8	7,2	654	<b>RKP 155</b>
<b>M 160 x 3</b>	235	47	206	161	7	6	87,2	8,0	698	<b>RKP 160</b>

**AWT - Ringkolbenpressen**  
**AWT-Hydraulic nuts**

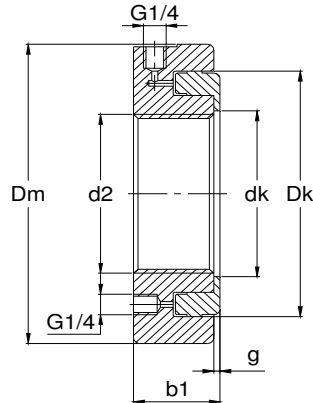

d <sub>2</sub>	Abmessungen						Gewicht	Aufpreßkraft bei 800 bar	Kurzzeichen Ringkolbenpressen	
	D <sub>m</sub>	b <sub>1</sub>	D <sub>k</sub>	d <sub>k</sub>	g	kolbenfläche				
mm						cm <sup>2</sup>	kg	kN		
<b>M 165 x 3</b>	240	47	211	166	7	6	92,3	8,2	739	<b>RKP 165</b>
<b>M 170 x 3</b>	245	48	216	171	7	6	94,7	8,6	758	<b>RKP 170</b>
<b>M 180 x 3</b>	255	48	227	181	7	6	103,0	9,1	824	<b>RKP 180</b>
<b>M 190 x 3</b>	270	50	240	191	8	8	116,0	10,5	928	<b>RKP 190</b>
<b>M 200 x 3</b>	280	50	251	201	8	8	125,0	11,5	1000	<b>RKP 200</b>
<b>Tr 205 x 4</b>	290	51	258	207	8	8	132,2	12,3	1058	<b>RKP 205</b>
<b>Tr 210 x 4</b>	295	52	263	212	9	9	135,0	12,7	1080	<b>RKP 210</b>
<b>Tr 215 x 4</b>	300	53	268	217	9	9	137,7	13,2	1102	<b>RKP 215</b>
<b>Tr 220 x 4</b>	305	53	273	222	9	9	144,2	13,5	1154	<b>RKP 220</b>
<b>Tr 225 x 4</b>	315	54	282	227	9	#	153,0	15,0	1224	<b>RKP 225</b>
<b>Tr 230 x 4</b>	320	54	287	232	9	#	160,0	15,3	1280	<b>RKP 230</b>
<b>Tr 235 x 4</b>	325	54	290	237	9	#	161,7	15,5	1294	<b>RKP 235</b>
<b>Tr 240 x 4</b>	330	55	296	242	9	#	165,3	16,1	1323	<b>RKP 240</b>
<b>Tr 250 x 4</b>	345	56	310	252	10	#	182,2	18,0	1458	<b>RKP 250</b>
<b>Tr 260 x 4</b>	355	57	319	262	10	#	188,0	19,0	1504	<b>RKP 260</b>
<b>Tr 270 x 4</b>	370	58	332	272	10	#	196,0	21,1	1568	<b>RKP 270</b>
<b>Tr 275 x 4</b>	375	58	337	277	10	#	204,0	21,5	1632	<b>RKP 275</b>
<b>Tr 280 x 4</b>	380	59	342	282	10	#	211,7	22,3	1694	<b>RKP 280</b>
<b>Tr 290 x 4</b>	390	60	352	292	10	#	218,3	23,3	1747	<b>RKP 290</b>
<b>Tr 295 x 4</b>	400	60	362	297	10	#	230,0	25,0	1840	<b>RKP 295</b>
<b>Tr 300 x 4</b>	405	61	365	302	10	#	237,0	25,8	1896	<b>RKP 300</b>
<b>Tr 310 x 5</b>	415	62	375	312	10	#	249,0	27,0	1992	<b>RKP 310</b>
<b>Tr 315 x 5</b>	420	62	380	317	10	#	252,5	27,5	2020	<b>RKP 315</b>
<b>Tr 320 x 5</b>	430	63	389	322	10	#	264,0	29,9	2112	<b>RKP 320</b>
<b>Tr 330 x 5</b>	440	64	398	332	11	#	270,8	31,0	2166	<b>RKP 330</b>

**AWT - Ringkolbenpressen**  
**AWT-Hydraulic nuts**

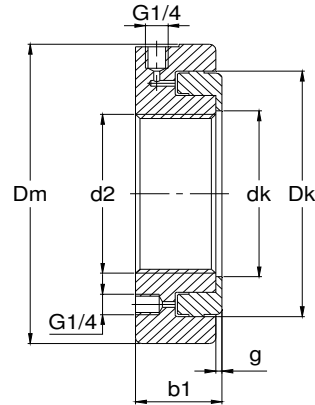

d <sub>2</sub>	Abmessungen						Gewicht	Aufpreßkraft bei 800 bar	Kurzzeichen Ringkolbenpressen
	D <sub>m</sub>	b <sub>1</sub>	D <sub>k</sub>	d <sub>k</sub>	g	kolbenfläche			
mm						cm <sup>2</sup>	kg	kN	
<b>Tr 335 x 5</b>	445	65	403	337	11	# 275,0	32,0	2200	<b>RKP 335</b>
<b>Tr 340 x 5</b>	450	65	408	342	11	# 284,0	32,5	2272	<b>RKP 340</b>
<b>Tr 345 x 5</b>	455	66	413	347	11	# 288,0	33,5	2304	<b>RKP 345</b>
<b>Tr 350 x 5</b>	465	66	422	352	11	# 306,0	35,0	2448	<b>RKP 350</b>
<b>Tr 355 x 5</b>	470	67	427	357	11	# 304,0	36,5	2432	<b>RKP355</b>
<b>Tr 360 x 5</b>	475	67	431	362	11	# 313,0	37,0	2504	<b>RKP 360</b>
<b>Tr 365 x 5</b>	482	67	436	367	11	# 317,0	38,0	2536	<b>RKP 365</b>
<b>Tr 370 x 5</b>	490	68	444	372	11	# 323,0	40,0	2584	<b>RKP 370</b>
<b>Tr 375 x 5</b>	495	68	450	377	11	# 334,0	41,0	2672	<b>RKP 375</b>
<b>Tr 380 x 5</b>	500	69	454	382	11	# 337,0	41,5	2696	<b>RKP 380</b>
<b>Tr 385 x 5</b>	505	69	460	387	11	# 348,0	42,0	2784	<b>RKP 385</b>
<b>Tr 395 x 5</b>	512	69	470	397	11	# 356,0	43,0	2848	<b>RKP 395</b>
<b>Tr 400 x 5</b>	525	71	477	402	11	# 368,0	47,0	2944	<b>RKP 400</b>
<b>Tr 410 x 5</b>	535	71	485	412	11	# 382	48	3056	<b>RKP 410</b>
<b>Tr 415 x 5</b>	540	71	490	417	11	# 386	49	3088	<b>RKP 415</b>
<b>Tr 420 x 5</b>	545	72	495	422	12	# 390	50	3120	<b>RKP 420</b>
<b>Tr 430 x 5</b>	555	74	505	432	12	# 398	52	3184	<b>RKP 430</b>
<b>Tr 435 x 5</b>	560	74	510	437	12	# 403	53	3224	<b>RKP 435</b>
<b>Tr 440 x 5</b>	565	74	519	442	12	# 425	54	3400	<b>RKP 440</b>
<b>Tr 450 x 5</b>	580	76	530	452	12	# 442	58	3536	<b>RKP 450</b>
<b>Tr 460 x 5</b>	590	76	540	462	12	# 450	60	3600	<b>RKP 460</b>
<b>Tr 470 x 5</b>	600	76	550	472	12	# 459	61	3672	<b>RKP 470</b>
<b>Tr 480 x 5</b>	612	76	560	482	12	# 460	63	3680	<b>RKP 480</b>
<b>Tr 490 x 5</b>	625	80	575	492	13	# 506	69	4048	<b>RKP 490</b>
<b>Tr 500 x 5</b>	635	80	585	502	13	# 523	70	4185	<b>RKP 500</b>

**AWT - Ringkolbenpressen**  
**AWT-Hydraulic nuts**

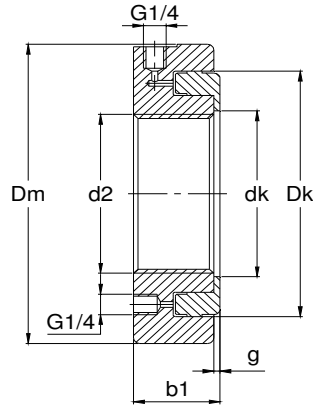

d <sub>2</sub>	Abmessungen						Gewicht	Aufpreßkraft bei 800 bar	Kurzzeichen Ringkolbenpressen	
	D <sub>m</sub>	b <sub>1</sub>	D <sub>k</sub>	d <sub>k</sub>	g	kolbenfläche				
mm						cm <sup>2</sup>	kg	kN		
<b>Tr 510 x 6</b>	645	80	595	512	13	#	533	72	4264	<b>RKP 510</b>
<b>Tr 520 x 6</b>	657	80	605	522	13	#	542	75	4336	<b>RKP520</b>
<b>Tr 530 x 6</b>	670	83	617	532	13	#	562	80	4496	<b>RKP 530</b>
<b>Tr 540 x 6</b>	680	83	628	542	13	#	581	83	4648	<b>RKP 540</b>
<b>Tr 550 x 6</b>	692	83	639	552	13	#	592	85	4736	<b>RKP 550</b>
<b>Tr 560 x 6</b>	705	83	650	562	13	#	612	88	4896	<b>RKP 560</b>
<b>Tr 570 x 6</b>	715	85	660	572	13	#	631	92	5048	<b>RKP 570</b>
<b>Tr 580 x 6</b>	725	85	670	582	13	#	641	93	5128	<b>RKP 580</b>
<b>Tr 590 x 6</b>	740	85	685	592	13	#	666	98	5328	<b>RKP 590</b>
<b>Tr 600 x 6</b>	750	85	695	603	13	#	677	100	5416	<b>RKP 600</b>
<b>Tr 610 x 6</b>	760	88	705	613	14	#	687	104	5496	<b>RKP 610</b>
<b>Tr 625 x 6</b>	775	88	720	628	14	#	702	107	5516	<b>RKP 625</b>
<b>Tr 630 x 6</b>	780	88	725	633	14	#	728	109	5824	<b>RKP 630</b>
<b>Tr 650 x 6</b>	805	88	748	653	14	#	763	115	6104	<b>RKP 650</b>
<b>Tr 655 x 6</b>	810	88	753	658	14	#	768	116	6144	<b>RKP 655</b>
<b>Tr 670 x 6</b>	825	90	768	673	14	#	795	121	6360	<b>RKP 670</b>
<b>Tr 680 x 6</b>	837	90	780	683	14	#	819	124	6552	<b>RKP 680</b>
<b>Tr 690 x 6</b>	850	90	792	693	14	#	844	128	6752	<b>RKP 690</b>
<b>Tr 695 x 6</b>	855	93	798	698	14	#	862	133	6896	<b>RKP 695</b>
<b>Tr 710 x 7</b>	870	93	812	713	14	#	877	136	7020	<b>RKP 710</b>
<b>Tr 720 x 7</b>	883	95	825	723	15	#	928	144	7424	<b>RKP 720</b>
<b>Tr 740 x 7</b>	910	95	848	743	15	#	991	154	7928	<b>RKP 740</b>
<b>Tr 750 x 7</b>	922	96	862	753	15	#	1033	160	8265	<b>RKP 750</b>
<b>Tr 760 x 7</b>	935	96	872	763	15	#	1045	165	8360	<b>RKP 760</b>
<b>Tr 780 x 7</b>	955	98	890	783	15	#	1068	172	8544	<b>RKP 780</b>

**AWT - Ringkolbenpressen**  
**AWT-Hydraulic nuts**

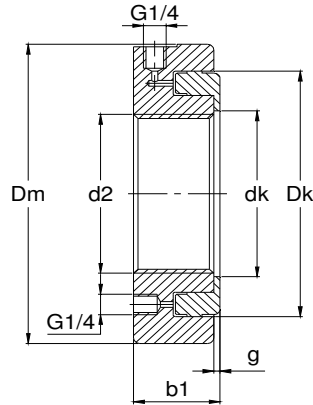

d <sub>2</sub>	Abmessungen						Gewicht	Aufpreß- kraft bei 800 bar	Kurzzeichen Ringkolben- pressen
	D <sub>m</sub>	b <sub>1</sub>	D <sub>k</sub>	d <sub>k</sub>	g	kolben- fläche			
mm						cm <sup>2</sup>	kg	kN	
<b>Tr 800 x 7</b>	970	98	909	803	16	# 1079	170	8632	<b>RKP 800</b>
<b>Tr 830 x 7</b>	1000	98	938	833	16	# 1101	176	8808	<b>RKP 830</b>
<b>Tr 850 x 7</b>	1020	98	960	853	16	# 1156	180	9248	<b>RKP 850</b>
<b>Tr 880 x 7</b>	1050	98	988	883	16	# 1148	185	9184	<b>RKP880</b>
<b>Tr 900 x 7</b>	1070	100	1012	903	16	# 1251	194	10008	<b>RKP 900</b>
<b>Tr 930 x 8</b>	1100	100	1042	933	16	# 1290	200	10320	<b>RKP 930</b>
<b>Tr 950 x 8</b>	1120	100	1065	953	16	# 1365	210	10920	<b>RKP 950</b>
<b>Tr 1000 x 8</b>	1170	100	1123	1003	16	# 1490	228	11920	<b>RKP 1000</b>
<b>Tr 1060 x 8</b>	1255	115	1185	1063	18	# 1610	300	12880	<b>RKP 1060</b>
<b>Tr 1080 x 8</b>	1280	118	1207	1083	18	# 1680	322	13440	<b>RKP 1080</b>
<b>Tr 1120 x 8</b>	1340	125	1260	1123	19	# 1900	392	15200	<b>RKP 1120</b>
<b>Tr 1180 x 8</b>	1430	135	1315	1183	22	# 2100	503	16800	<b>RKP 1180</b>