

AWT - VIERPUNKTLAGER
AWT - FOUR-POINT CONTACT BEARING

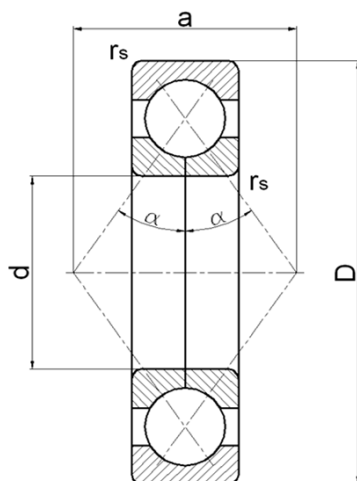

Druckwinkel $\alpha=35^\circ$

Abmessungen Dimensions				rs min	Tragzahlen Load Ratings		Grenzdrehzahl Speed limit	Gewicht Weight	Type Designation
d	D	B	a		Cr	C ₀			
mm				mm	KN	KN	Öl oil		
							min ⁻¹	Kg	
25	62	17	31	1,1	44	31,5	14000	0,252	QJ305M
30	62	16	32	1	36,5	27	20000	0,302	QJ206M
30	72	19	36	1,1	58,5	43	11000	0,372	QJ306M
35	72	17	38	1,1	41,5	35,5	18000	0,464	QJ207M
35	80	21	41	1,5	62	51	9500	0,497	QJ307M
40	80	18	42	1,1	54	45,5	9500	0,388	QJ208M
40	90	23	46	1,5	86,5	68	8500	0,689	QJ308M
45	85	19	45	1,1	64	57	8500	0,482	QJ209M
45	100	25	51	1,5	102	83	7500	0,947	QJ309M
50	90	20	49	1,1	58,5	56	13000	0,641	QJ210M
50	110	27	56	2	110	91,5	11000	1,37	QJ310M
55	100	21	54	1,5	75	75	7000	0,682	QJ211M
55	120	29	61	2	127	108	10000	1,74	QJ311M
60	110	22	60	1,5	91,5	93	6300	0,869	QJ212M
60	130	31	67	2,1	146	127	9000	2,18	QJ312M
65	120	23	65	1,5	104	100	9500	1,24	QJ213M
65	140	33	72	2,1	163	146	8500	2,69	QJ313M
70	125	24	68	1,5	118	132	5600	1,39	QJ214M
70	150	35	77	2,1	183	166	8000	3,25	QJ314M
75	130	25	72	1,5	125	129	5300	1,77	QJ215M
80	140	26	77	2	132	137	8000	1,8	QJ216M
85	150	28	82	2	153	160	7000	2,25	QJ217M